

MONITORS

PYTHON®



MONITORS

Python®

- Seamless brass 2.5" waterway for flows up to 1250 gpm
- Flexible installation options
 - Extensive base options
 - Two choices in manual controls — tiller or steering wheel
 - Hydrant mounting option
- All construction features designed to minimize maintenance needs
 - Corrosion resistant brass construction
 - Cast brass swivel joints
 - Bronze balls in all swivel joints
 - Stainless steel handles
 - Grease zerks for easy lubrication
- Positive twist locks for both vertical and horizontal movement



5-39



Seamless tube

Tiller control
allows fast action
changes

1250
GPM

FM

CE

SPECIFICATIONS					
Max. GPM (LPM)	1250 (4732)				
Inlets	Sizes		Types		
	6"	150# ANSI Flange			
	4"	150# ANSI Flange	300# ANSI Flange	NPT (F)	
	3"	150# ANSI Flange	300# ANSI Flange	NPT (F)	
	2.5"	150# ANSI Flange	300# ANSI Flange	NPT (F)	NHT (F) (hydrant)
Outlet Size	2.5" NHT				
Controls	Steering wheel				
	Tiller				
Material/Finish	Brass with red urethane enamel or chrome-plated				
Friction Loss	24 psi at 1250 gpm				
	18 psi at 1000 gpm				
	11 psi at 750 gpm				
Travel	V -45° to +90° (135°)				
	H 360° (continuous)				
Weight	45.00 Lbs. (See specification chart)				
Ratings and Certifications	FM Approved, CE				

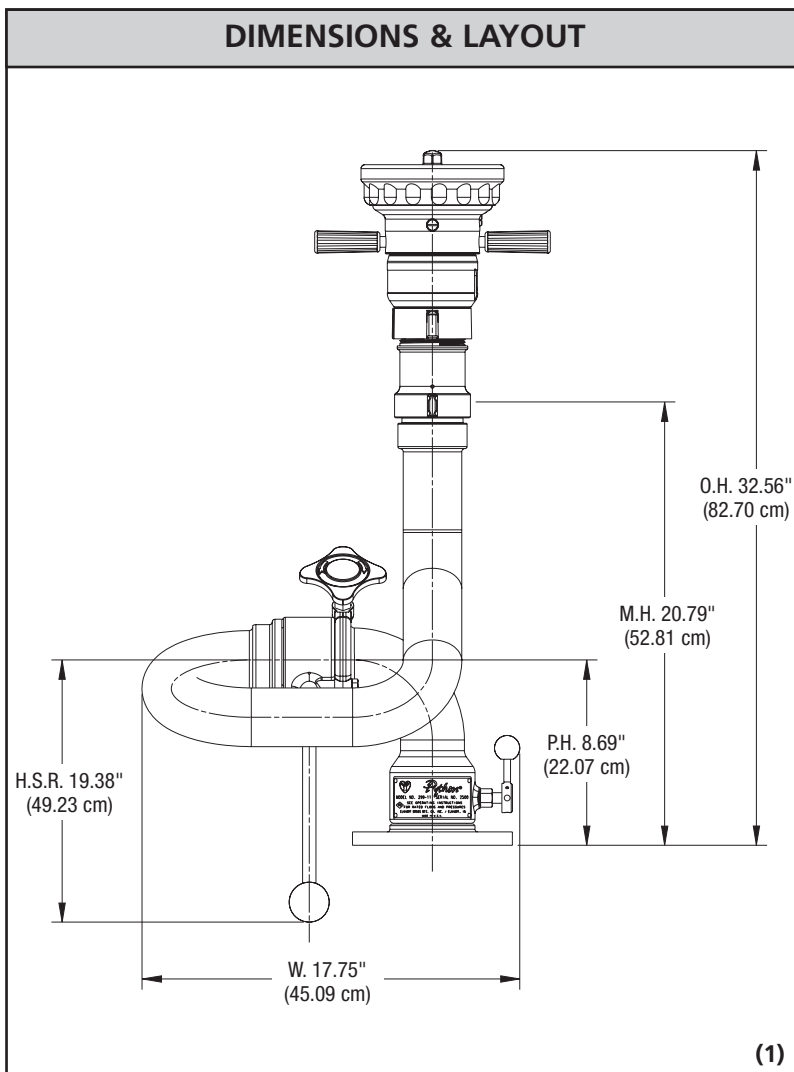

KEY CONFIGURATIONS (ACCESSORIES)

HYDRANT MOUNT (2)



STEERING WHEEL HANDLE (3)



PRESSURE GAUGE (4)



ADDITIONAL INFORMATION

- All flanges specified with the monitor are flat faced. Raised face flanges are available with some inlet sizes. Please inquire with our sales staff.
- Technical Data on monitor performance may be found on page T-10.
- The Python® is also available in a portable cart version. Please see page 5-61 for details.
- Hydrant – hydrant swivel connection attaches to 2.5" hydrant nipple (includes elbow assembly and support rods.)



PYTHON®

MONITORS

Python® Selector Guide





MONITOR TYPE	INLETS												OUTLET SIZE	MAX. GPM (LPM)		CONTROLS			CERT.	DIMENSIONS (STANDARD) (INCHES)			FINISHES			Model				
	SIZES / TYPES (INCHES)													2.5"	1250 (4732)	750 (2839)	Pressure Gauge	Steering Wheel		Tiller Bar	CE	FM Approved	Width	Depth	Height		Weight (Lbs.)	Red Urethane	Chrome-plated	Illustration
	NHT*			NPT			150# ANSI FLANGE			300# ANSI FLANGE																				
	2.5	2.5	3	4	2.5	3	4	6	2.5	3	4	2.5																		
Standard		o	o	o	o	o	s	o	o	o	o	o	o	•	•	o			o							s				
		o	o	o	o	o	s	o	o	o	o	o	o	•	•	o	o	s	•	•	18.0	31.5	17.5	45.0	•	•	•	299-11P		
Hydrant	s													•	•	o		s	•	•	17.75	31.5	25.5	60.75	•	•	2	299-11H		
																4	3	1											Illustration	

* Swivel KEY s = standard o = option

Components & Options Chart

COMPONENTS & OPTIONS		ILLUSTRATION	MODEL
Companion Flange Kits	3" 150# ANSI steel flange includes bolts and gaskets		81315001
	4" 150# ANSI steel flange includes bolts and gaskets		81317001
Drain Valve	Automatic ball drip drain valve.		702

Recommended Products

CSW-C-HF – SELF-EDUCTING	SM-1250B – X-STREAM®	CJN-B – SELECT-O-STREAM®	SM-1000HF – SELF-EDUCTING
			
Page 6-14	Page 6-7	Page 6-10	Page 6-14
84 – BUTTERFLY WAFER VALVE	296 – HYDRANT BASE	181 – DELUGE TIP	282B – STREAM SHAPER
			
Page 5-73	Page 5-73	Page 1-29	Page 1-27